

Assembly Instruction

Disconnect power before wiring.

Keep removed piece parts at a safe place to have them ready for reassembling.

1. Loosen cover screws and remove cover.
2. Loosen cable clamp screws and remove cable clamp.
3. Insert cord into PVC-guard.
4. Strip the outer jacket as shown in diagram. Make sure not to damage insulation conductors.
5. Strip each insulation conductors as shown in diagram.
6. Loosen contact screws but do not remove screws.
7. Connect green or green/yellow (ground) wire to center clamp marked with ground symbol .
8. Connect blue (white or light grey) wire to clamp marked „N“ (neutral).
9. Connect brown (black / “hot”) wire to clamp marked „L“ (line).
10. Tighten all contact screws with a torque of 0.5 Nm (4.5inlbs).
11. Insert shoulder of PVC-guard into cutout of base unit.
12. Assemble cable clamp over cut-off end of outer jacket of the cord and tighten cable clamp screws with a torque of 0.34Nm (3inlbs)
13. Assemble cover and tighten screws with a torque of 0.3 Nm (2.7inlbs)

Warning: Failure to wire as instructed may cause personal injury or damage to device or equipment. To be installed or checked by a qualified person only.

Strip lengths			
Outer Jacket	A	B	C
30mm	9mm	26mm	30mm

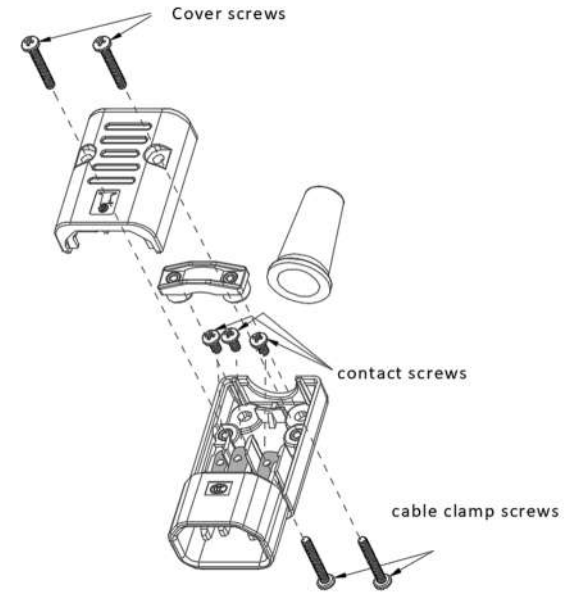
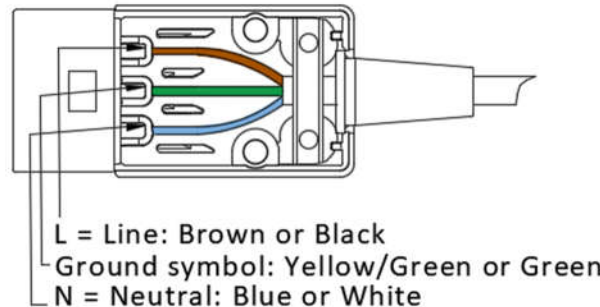
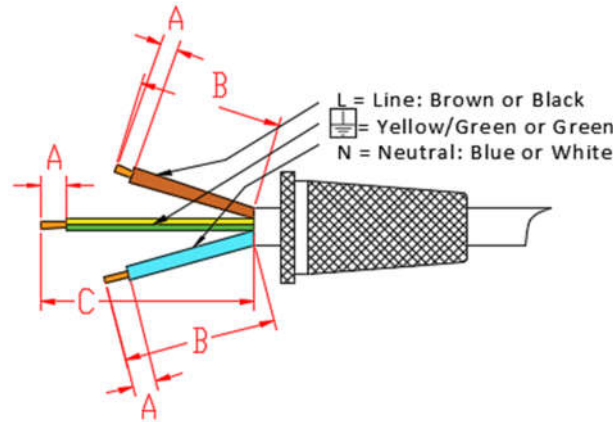

Applicable cable size and type.		
16/3 or 14/3 AWG	SJT	U.S./CA
0.75mm ² or 1.0mm ²	H05/RVV	EU/China
1.0mm ²	H07	EU

The maximum wire size depends on the maximum cable diameter. The PVC guard maximum diameter is 9.4mm.