

PANEL THICKNESS:  
0.99-6.35mm

ROCKER MARKING

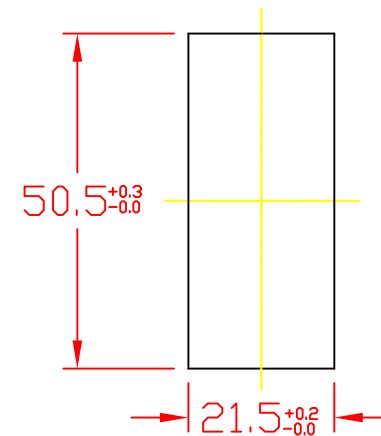
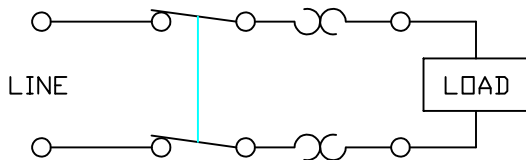
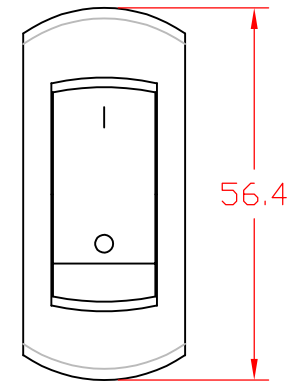

Trip Current is 140% of rated current.  
Tripping time in seconds at 73°F(23°C) at various overload levels:

OVERLOAD LEVEL:	100%	200%	300%	400%	500%	600%	1000%
15A Rating:	No Trip	8-30'	2.5-10'	1.5-4.5'	1-3'	0.7-2'	0.3-0.9'

THIS DOCUMENT AND ITS CONTENTS ARE THE PROPRIETARY CONFIDENTIAL PROPERTY OF INTERPOWER CORPORATION. NO USE OR COPIES MAY BE MADE WITHOUT WRITTEN PERMISSION FROM INTERPOWER CORPORATION.

DIMENSIONS IN MILLIMETERS

TITLE 15A Circuit Breaker

DRAFT BY: DDF DATE: 12-14-20

PART NUMBER: 82910081

DRAFTING APPROVAL: DDF DATE: 12-14-20

MATERIAL:

DO NOT SCALE

INTERPOWER CORPORATION

REV	CHANGE DESCRIPTION	DATE
A	Introduction of part replacing 82910080. DDF	12/14/20

SHEET 1 OF 1