

NOTE 1: RECOMMENDED DIAMETER FOR THRU-HOLE (SCREW/NUT COMBINATION) HARDWARE MOUNTING METHOD. OTHER METHODS WILL REQUIRE HOLES WITH DIFFERENT DIMENSIONS AND PARAMETERS.

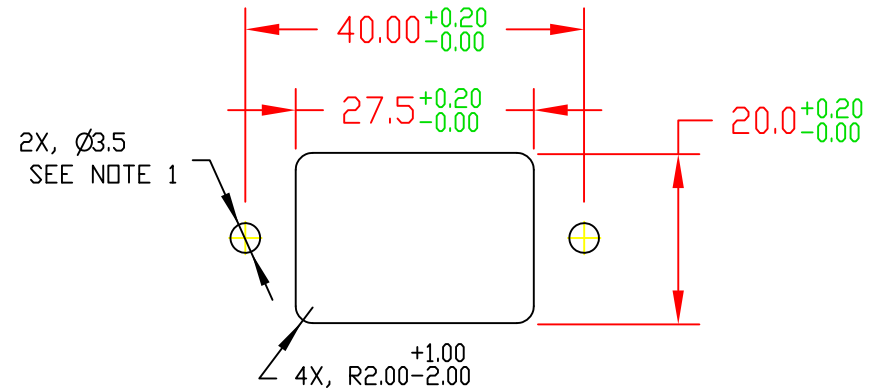

PANEL CUTOUT
FRONT SIDE MOUNTING

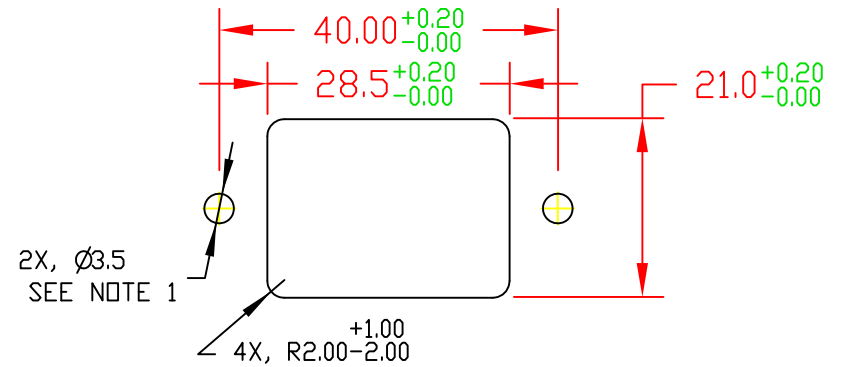

PANEL CUTOUT
REAR SIDE MOUNTING

THIS DOCUMENT AND ITS CONTENTS ARE THE PROPRIETARY CONFIDENTIAL PROPERTY OF INTERPOWER CORPORATION. NO USE OR COPIES MAY BE MADE WITHOUT WRITTEN PERMISSION FROM INTERPOWER CORPORATION.

DIMENSIONS IN MILLIMETERS

TITLE: C18 Screw Mount Inlet with Solder Tabs

DRAFT BY: DDF DATE: 07/20/16

PART NUMBER: 83030310

DRAFTING APPROVAL: JPC DATE: 07/21/16

MATERIAL:

DD NOT SCALE

INTERPOWER CORPORATION

DATE

INITIALS

SHEET 1 OF 1

REV

CHANGE DESCRIPTION

B	Added the N. American ratings to face view.	10/11/16	DDF
A	Introduction of Interpower Corporation manufactured part.	07/20/16	DDF