

Face can be rotated during assembly to achieve 8 different right angle configurations.

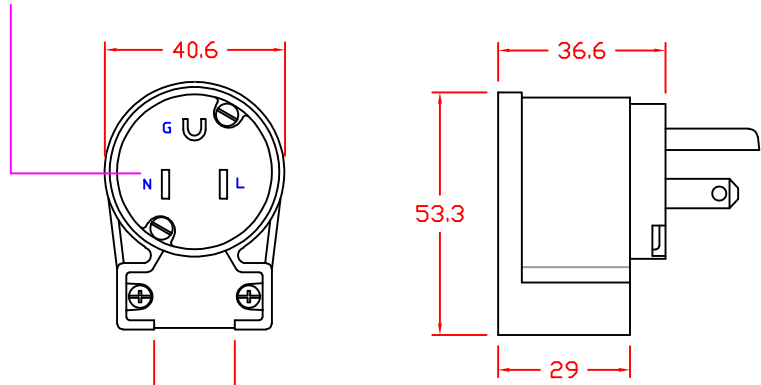

Cable Accommodation:
7.6 to 16.6mm

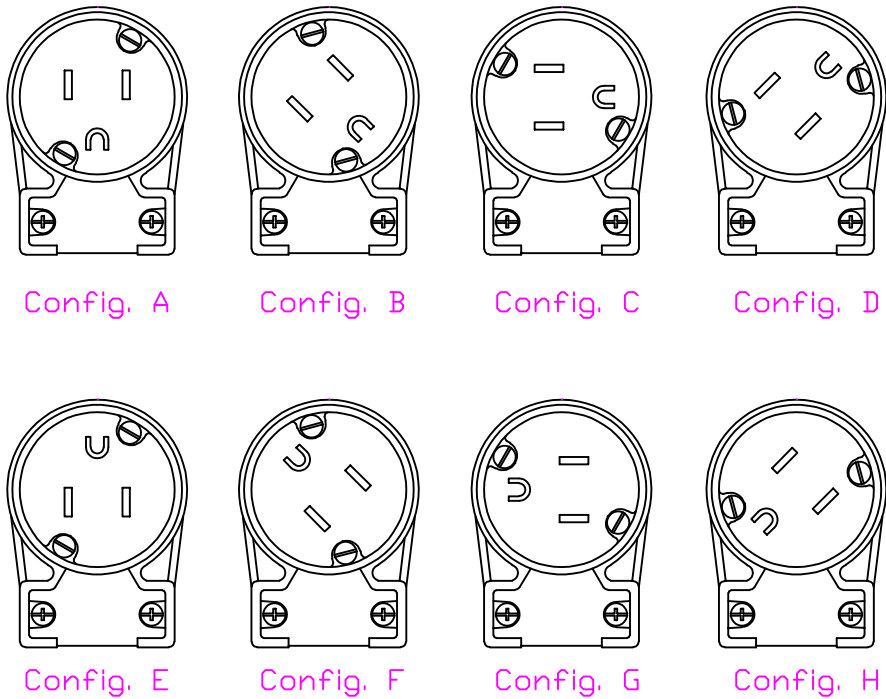

WARNING: TO AVOID FIRE, SHOCK, OR DEATH; UNPLUG CORD OR TURN OFF POWER AT CIRCUIT BREAKER OR FUSE. TEST THAT POWER IS OFF BEFORE WIRING! Use this device only with copper or copper clad wire.

1. This device enables wiring in 8 different cover orientations to accommodate your specific application. Consider which orientation you require before proceeding.
2. Strip cord jacket and cut fillers approximately 1-3/8" from the end. Cut conductors according to desired cover orientation and to terminal positions. Strip insulation to expose 9/16" bare copper at end of each conductor.
3. Separate housing from body and remove strain relief clamp.
4. Twist all strands of each conductor tightly together (**Do Not Solder Ends of Wire**) and insert into proper wire terminal. Holding each conductor in terminal housing, tighten terminal screw firmly. **CAUTION: Terminal screws must tighten onto conductor only, not insulation.** Tighten terminal screws to 10-12 inch-lbs.
5. Re-attach housing to body by aligning to desired position. Tighten assembly screw to 12-14 inch-lbs. Firmly secure strain relief onto body with clamping screws. Make sure that cord jacket is being clamped uniformly while securing clamp. Tighten cord clamp screws to 12-14 inch-lbs. The strain relief will accommodate cords from 18/3 SJ to 10/3 S (with outer diameter from 0.30" to 0.60").

TO BE INSTALLED AND USED IN ACCORDANCE WITH APPROPRIATE ELECTRICAL CODES AND REGULATIONS.

THIS DOCUMENT AND ITS CONTENTS ARE THE PROPRIETARY CONFIDENTIAL PROPERTY OF INTERPOWER CORPORATION. NO USE OR COPIES MAY BE MADE WITHOUT WRITTEN PERMISSION FROM INTERPOWER CORPORATION.				DIMENSIONS IN MILLIMETERS		TITLE Plug	
				DRAFT BY: JPC/DDF DATE: 8/2/23		PART NUMBER: 88030100A	
				DRAFTING APPROVAL: DDF DATE: 8/2/23			
B	Added face position options & instructions.	8/2/23	DDF	MATERIAL:		DO NOT SCALE	
A	Part Introduction	2/21/01	DDF			SHEET 1 OF 1	
REV	CHANGE DESCRIPTION	DATE	INITIALS				